

COPPARD

PLANT HIRE LIMITED

Crowborough Tel: 01892 662777

Godstone Tel: 01883 743322

Brighton Tel: 01273 596979

www.coppard.co.uk

Glassboy 500

- Counterbalanced floor crane with hydraulic lifting arm.
- Ideal for shop front glazing and fitting below overhangs when fitted with a vacuum lifter.
- Can be used between floors for raising loads from the ground when fitted with electric hoist.
- Easily assembles and disassembles for transport.
- Lockable wheels
- Capacity 500kg
- Max hook height 2.76m

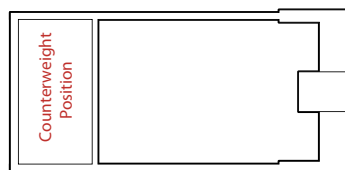
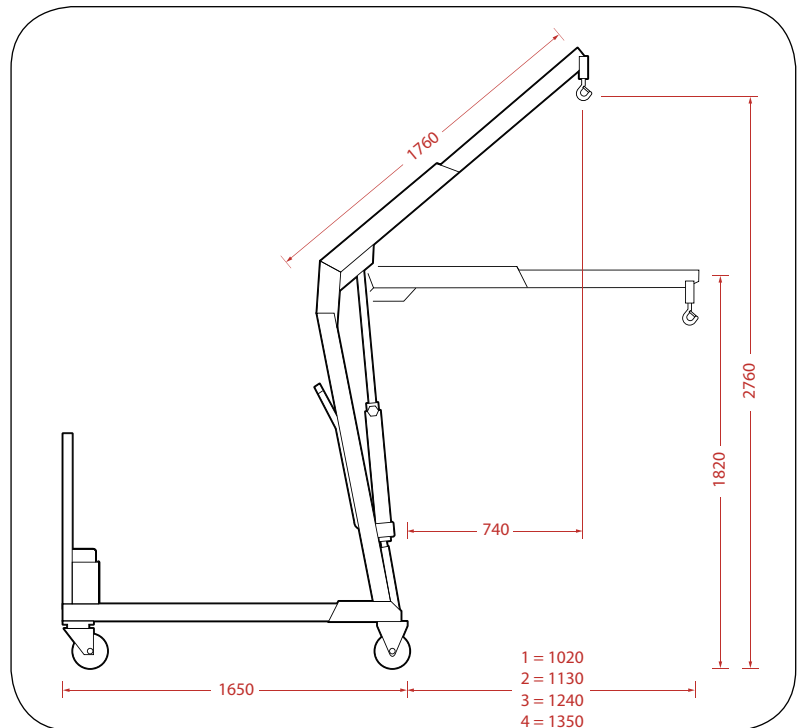

Technical Specifications

Capacity Pos 1	500kg
Capacity Pos 2	420kg
Capacity Pos 3	370kg
Capacity Pos 4	300kg
Weight without counterweights:	130kg
Weight with counterweights:	706kg
Counterweights:	24

